

T/SP/NP/14/E



SPECIFICATION FOR

**THE DESIGN OF SYSTEM EXTENSIONS,
CONNECTIONS AND SERVICES TO BELOW 7 BAR
WALES & WEST UTILITIES SYSTEMS**

JANUARY 2008

CONTENTS	Page
FOREWORD	3
BRIEF HISTORY	3
END NOTE	3
1. SCOPE	5
2. PURPOSE	5
3. ASSUMPTIONS	5
4. SEPCIFICATION	5
APPENDICES	
A STANDARD DESIGN TABLES	8
B SPECIFICATION FOR THE DESIGN OF PIPES	15
C EVALUATION & DESIGN OF CONNECTIONS TO NON-TYPICAL DEMANDS	22
D SPECIFICATION FOR STANDARD PIPE CODE TABLE FOR NEW LAY PIPES	30

FOREWORD

This specification was approved by Asset Compliance Manager 16th January, 2008 for use by Managers, Engineers & Supervisors throughout Wales & West Utilities.

Documents are revised, when necessary, by the issue of new editions. Users should ensure that they are in possession of the latest edition by referring to the Document Library of Documents available on the Company Intranet.

Compliance with this document does not confer immunity from prosecution for breach of statutory or other legal obligations.

BRIEF HISTORY

First Published as T/SP/NP14/E	May 2006	EPSG/T05/1665
Re-issued to correct minor errors	June 2007	EPSG/T06/1801
Rebranded & updated for clarification	July 2007	
Amended to include 40mm MDPE for new LP & MP services	January 2008	

KEY CHANGES (Identify the changes from the previous version(s) of this document)

Section	Amendments
Appendix A	Table A.2 Red cells now replaced with grey to aid black & white printing. Penultimate para should read 'Loads within the shaded...
	Table A.5 40mm replacing 63mm in the standard service designs for LP networks
	Table A.7 Additional row added to include 40mm MDPE services up to $\leq 695\text{kwh} / \leq 65 \text{ scmh}$
	Table A.8 error in demand threshold descriptions 4 th /5 th and 6 th rows properly described as <=433KW (U40) <=693KW (U65) <=1083KW (U100) respectively
Appendix B	Table B.1 description of tier. '<=65mb, >65mb'65 should now be replaced with 105 to correctly align with Table A.3
Appendix D	Table D.1 The inclusion of 40mm within the PE pipes table

DISCLAIMER

This document is provided for use by Wales & West Utilities and such of its contractors as are obliged by the terms of their contracts to comply with this engineering document. Where this document is used by any other party it is the responsibility of that party to ensure that the engineering document is correctly applied.

MANDATORY AND NON-MANDATORY REQUIREMENTS

In this document:

must: indicates a mandatory requirement.

should: indicates best practice and is the preferred option. If an alternative method is used then a suitable and sufficient risk assessment must be completed to show that the alternative method delivers the same, or better, level of protection.

ENDNOTE

Comments

Comments and queries regarding the technical content of this document should be directed to:

Asset Management Dept
Wales & West Utilities
Wales & West House
Spooner Close
Celtic Springs
Coedkernew
NEWPORT
NP10 8FZ

Buying Documents

Contractors and other external users should direct their requests for further copies of Wales & West Utilities documents to the department or group responsible for the initial issue of their contract documentation.

© Wales & West Utilities

This document is copyright and must not be reproduced in whole or in part by any means without the approval in writing of Wales & West Utilities.

SPECIFICATION FOR THE DESIGN OF SYSTEM EXTENSIONS, CONNECTIONS AND SERVICES TO BELOW 7 BAR WALES & WEST UTILITIES SYSTEMS

1. SCOPE

This Specification is for use in:

- The design of all new mains, services and mains risers
- The review of designs submitted by third parties for evaluation
- The evaluation of new, or increased loads where there are no new pipes to be installed.

2. PURPOSE

The purpose of this specification is to provide a consistent and defensible approach to the sizing of services, connections and the quotation of design pressures.

3. ASSUMPTIONS

This document defines how the physical design of any pipe, subject to a new or modified demand, which is to be connected to a Wales & West Utilities parent main, shall be undertaken.

The connection for all demands, including Condition 16 (C16) loads, is to be designed in accordance with this document.

Interruptible supply requests should be evaluated in accordance with T/PR/NP/3.

4. SPECIFICATION

This Specification consists of a number of Appendices. Explanatory notes are contained in all Appendices to guide the Responsible and Competent person; however the purpose of this section is to provide an overview of when to use any particular Appendix for a specific activity.

4.1 Requirement for Network Analysis

All requests received for new loads or increased loads shall be assessed to determine if network analysis is required at the quotation stage. Refer to Appendix A Table A.1.

If the request falls outside the scope of Table A.1 it shall be referred for network analysis e.g. if the load is to be taken from the IP system or is a non-typical demand.

Standard or guaranteed pressures have been developed, to avoid the need to undertake network analysis at the quotation stage. The scope of guaranteed capacity extends to all LP and MP requests up to 1733KW/160scmh with the exception of non typical loads and those LP requests >900KW <=1733KW off <=2" mains.

Refer to Appendix A, Tables A.2 and A.3.

Post acceptance security of supply assessment may be required when standard pressures have been taken from Tables A.2 and A.3. "Security of Supply" (SoS) checks that require referral to network analysis are necessary when the load exceeds the threshold for network analysis using Appendix A, Table A.1

The "SoS" check shall be carried out to ensure that capacity is available to support the load increase. Any shortfall in capacity should be met, at Wales & West Utilities' cost, before the load can be connected.

The process for undertaking post acceptance "SoS" checks, and notifying the customer of any lead times for provision of capacity, shall be in accordance with connections and planning policies/procedures.

4.1.1 Minimum parent main pressures for LP networks

The values in Table A.2 represent the minimum pressures to be quoted where a multiple meter point connection is subject to network analysis as part of the quotation process.

4.1.2 Minimum parent main pressures for MP networks

The values in Table A.3 represent the minimum pressures to be quoted where a multiple meter point connection is subject to network analysis as part of the quotation process.

4.2 Design of services

Wherever possible services should be sized in accordance with standard tables.

Standard sizes do not preclude the reduction of nominal diameter for pipework and fittings at the service termination location. In these circumstances, it is not necessary to check the design in Toolbox.

All services shall be designed in accordance with Appendix B.

Pipe codes used in design tools shall be in accordance with Appendix D.

Additional or simplified requirements for specific areas of service design activities are outlined in the following sub sections.

4.2.1 New LP services

Standard service sizes, for the range $\leq 1085\text{kW}$ and $\leq 63\text{m}$, shall be quoted in accordance with the values shown in Appendix A Table A.5.

Above ground domestic service laterals $\leq 15\text{m}$ shall be sized in accordance with Appendix A, Table A.6.

4.2.2 Increased loads to existing LP services

Existing services, subject to a load increase, are permitted a maximum pressure drop of up to 5mbar where sufficient mains pressure is available.

The total revised load should be assessed against Table A.1 to determine any requirement for network analysis.

To assess whether a standard mains pressure can be utilised, reference shall be made to Appendix A, Table A.2, by comparing the total revised load (new plus existing) against mains size. If the total revised load request is $\leq 1083\text{kW}$ and the length $\leq 50\text{m}$ Appendix A Table A.8 should be used to determine if the existing service is to be replaced.

4.2.3 Replacement of services not subject to a load increase

Where an existing service is identified for replacement due to condition or policy, the process defined within the relevant management procedure should be used to identify the size of pipe to be installed.

4.2.4 New MP services

Standard service sizes, in the range $\leq 1085\text{kW}$ and $\leq 63\text{m}$, shall be sized in accordance with Table A.7.

4.3 Design of Mains

Mains shall be designed in accordance with Appendix B, and the pipe code table used in design tools shall be in accordance with Appendix D.

Additional or simplified requirements for specific areas of mains design activities are outlined in the following sub sections.

4.3.1 Standard LP/MP mains connection design sizes for UIP/GT connections

Where the connected load is $< 10835\text{kW}$ the standard connection, corresponding to the load size, shall be found in Table A.4.

4.3.2 Approved mains connections for all pressure tiers and work types

Manifold connections shall not be used. Mains connections to an existing system should use a Wales & West Utilities Approved, manufacturer's standard tee or fitting.

The method for connection shall be in accordance with Tables A.9 and A.10.

4.4 Non typical demands

A non-typical demand is a demand with a non-typical seasonal and/or daily profile for the customer type. Customers using compressors or boosters fall into this category.

It is important that sufficient information is gathered from the customer to properly assess the impact of non-typical demands on the upstream and downstream system network. Network analysis, including the use of such tools as Compass where necessary shall be carried out. Reference should be made to Appendix C.

APPENDIX A

STANDARD DESIGN TABLES

Table A.1: Network Analysis Threshold Table for Low & Medium Pressure Systems.

Identify the maximum permissible demand that may be taken from a parent main of defined diameter without the need for network analysis of the model.

Nominal Pipe Diameter	Maximum demand (kW / scmh) [PID for services / Pk6 for multiple premises sites]	
	LP: DMP < 19mb	MP: DMP > 65mb
≤ 2" / ≤ 50mm metallic ≤ 63mm / ≤ 2" PE	≤ 66 / 6	≤ 220 / 20
> 2" - ≤ 4" metallic	≤ 175 / 16	≤ 435 / 40
> 50mm - ≤ 125mm metallic		
> 63 - ≤ 125mm PE		
> 2" - ≤ 4" PE		
> 4" - ≤ 6" metallic	≤ 450 / 40	≤ 925 / 85
> 100 - ≤ 150mm metallic		
> 125 - ≤ 180mm PE		
> 4" - ≤ 6" PE		
> 6" - ≤ 8" metallic	≤ 900 / 85	≤ 1410 / 130
> 150 - ≤ 200mm metallic		
> 180mm - ≤ 250mm PE		
> 6" - ≤ 8" PE		
> 8" - ≤ 12" metallic	≤ 1735 / 160	≤ 1735 / 160
> 200 - ≤ 300mm metallic		
> 250mm - ≤ 355mm PE		
> 8" - ≤ 12" PE		
> 12" / 300mm metallic	≤ 2170 / 200	≤ 2170 / 200
> 355mm / > 12" PE		

This table should be used when considering all types of demands (multiple and single premises sites) where typical consumption behaviour is indicated as part of the connection request.

Single Premises Services: Using the diameter of the parent main, compare the maximum permissible demand with the requested PID. Where the PID does not exceed the indicated value, no additional network analysis is required & the design work should progress.

Multiple Premises Connections: For connections to be taken off the Medium Pressure network - Using the diameter of the parent main, find the maximum permissible demand for the relevant main and compare it with the requested demand. Where this does not exceed the indicated value, no network analysis is required as part of the quotation process. However for connections to be taken off the Low Pressure network refer to Table A.2.

Table A.2: Connection Point Pressures for Low Pressure Systems

Minimum pressure to be supplied for a given level of demand and parent main diameter - the segment within the box defined by the solid bold blue boundary line should be used to identify the supply pressure without reference to the network analysis model.

Max. Permissible Demand (kW/scmh)	≤175/≤16	≤450/≤40	≤900/≤85	≤1733/≤160	≤2160/≤200	≤3240/≤300	≤4325/≤400	≤5410/≤500	>5410/>500
	Nominal Diameter								
≤ 2" / ≤ 50mm metallic	23	23	23	23	25	26	26	26	Supply pressure to be agreed by negotiation with the customer (or their representative). The values in the previous column must be used as a start point and the agreed values must allow the efficient development of the overall system.
≤ 63mm / ≤ 2" PE									
>2" – ≤4" metallic	23	24	24	24	25	26	26		
>50mm – ≤100mm metallic									
>63 – ≤125mm PE									
>2" – ≤4" PE	23	24	25	25	25	26	26		
>4" – ≤6" metallic									
>100mm – ≤150mm metallic									
>125mm – ≤180mm PE									
>4" – ≤6" PE	23	24	25	25	25	26	26		
>6" – ≤8" metallic									
>150mm – ≤200mm metallic									
>180mm – ≤250mm PE	23	24	25	25	25	26	26		
>6" – ≤8" PE									
>8" – ≤12" metallic									
>200mm – ≤300mm metallic									
>250mm – ≤355mm PE	23	24	25	25	25	26	26		
>8" – ≤12" PE									
>12" / >300mm metallic									
>355mm / >12" PE	23	24	25	25	25	26	26	26	

Note: When considering discrete systems designed post December 1995, add 1.75mb to the stated values.

Loads that fall within the solid bold blue boundary are guaranteed capacity for all load types.

The pressures within the boundary define the standard connection point pressures for multiple meter point requests.

The cell pressures can be used as available pressure for new service designs ≥180mm diameter, (see note2 within Table B.1), and other service designs involving a mains element.

The values represent the minimum pressures to be quoted where a multiple meter point connection is subject to network analysis as part of the quotation process (see note1).

In the case of alternative to reinforcement deep connection points the minimum pressure relates to the pressure at the customer’s (downstream) end of the system extension.

Within the solid bold blue boundary non typical loads must still be assessed using network analysis,

however the pressures are applicable for non typical demand multiple meter point when used for Charging Point purposes only.

The values outside of the defined box define the minimum supply pressure and the charging point pressure for multiple premises sites where reference to the analysis model identifies the indicated pressure is not available.

Those multiple premises demands that are outside of the defined solid bold blue boundary shall be subjected to network analysis to identify the available pressure. The values in the table will be the minimum supply pressure for these types of request where the analysis model shows the table cell pressure is not available.

Loads falling within the shaded cells will be subject to a post-Acceptance capacity check (by Wales & West Utilities) to ensure security of supply.

For demands >5410kW / >500scmh the charging point pressure is 26mb.

Note: Wales & West Utilities will identify the instances and the circumstances, normally at post acceptance, where Wales & West Utilities may choose to re-negotiate the pressure provided, to develop overall lower costs of reinforcement and connection.

Table A.3: Connection Point Design Pressure (loads <2160KW/200scmh) and Minimum Supply Pressure for all MP mains extensions.

The values within this table represent the design pressure that should be used as the start pressure for the design of any connection that:

- Is for a load less than 200scmh including services, that is not subject to network analysis.
- Provides the minimum design supply pressure from the Wales & West Utilities parent main for a mains system extension.

Tier (DMP) \ Pressure	Minimum parent main supply pressure	Design Minimum mains pressure	Max Service pressure drop
MP = 270mb	400mb	350mb	70mb
MP = 180mb	350mb	250mb	70mb
MP = 105mb	240mb	140mb	35mb
MP = 65mb	150mb	100mb	35mb
MP = 35mb	95mb	70mb	35mb

The system Design Minimum Pressure (DMP) is dependant on the Medium Pressure tier. The grey shaded cells in the above table are not applicable to Medium Pressure networks at present.

The Minimum parent main pressures will be provided as the 'source' pressure for the design of the mains extension. However, they do NOT infer actual mains pressures to be maintained i.e. Wales & West Utilities may chose, post-Acceptance to modify the pipe(s) to meet operational requirements of the system, and will fund any subsequent changes.

When dealing with a UIP submission, any mains that Wales & West Utilities is requested to adopt must be designed to ensure the minimum mains pressure, as stated in the middle column, is maintained. Similarly, any service that Wales & West Utilities is to take ownership should be designed in accordance with the maximum pressure drops shown within Table B.1 and which have been included for easy reference in the right hand column above. The pressures represent the minimum to be available during peak demand conditions. The pressure may be less than that indicated at off-peak times. The minimum pressure will be identified for inclusion within the quotations document.

The minimum parent main supply pressures will also be the minimum design pressures to be provided for mains extensions, when network analysis is carried out for loads in excess of 200scmh.

The cell pressures represent the minimum parent main design pressures to be provided for mains extensions, and/or used for charging point purposes for all load sizes, where reference to the analysis model identifies the indicated pressure is not available.

Charging point pressures for services are taken as the design minimum mains pressure.

Wales & West Utilities may chose to upsize mains to be laid, and/or takes ownership, to provide enhanced mains extremity pressures (at Wales & West Utilities' cost) in accordance with the current agreement.

Post acceptance security of supply checks must be carried when the load/mains size combination would require network analysis in accordance with Table A.1.

Table A.4: Standard Connection Diameter for Multiple Premises Sites (Final connection for GT/UIP requests)

Wales & West Utilities will provide the default connection pipe diameter shown to supply multiple premises sites for the indicated maximum demand.

Max. Permissible Demand (kW) / (scmh)	LP: Diameter (mm)	MP: DMP≤65mb Diameter (mm)	MP: DMP≤105mb Diameter (mm)	MP: DMP>105mb Diameter (mm)
≤ 314 / 30	63	63	63	63
≤ 758 / ≤ 70	90	63	63	63
≤ 1100 / ≤ 100	90	63	63	63
≤ 1625 / ≤ 150	125	90	63	63
≤ 2167 / ≤ 200	125	90	63	63
≤ 3250 / ≤ 300	125	90	63	63
≤ 4333 / ≤ 400	180	125	63	63
≤ 5416 / ≤ 500	180	125	90	63
≤ 10835 / ≤ 1000	180	125	90	90
> 10835 / > 1000	By Negotiation			

The table values are the diameters to be used for quotation unless requested otherwise (note the value shown is the nominal diameter and may be subject to substitution with a material of similar effective diameter). Diameters greater than the value shown may be provided subject to additional cost. The grey shaded cells in the above table are not applicable to Medium Pressure networks at present.

The table values are the minimum values that will be accepted as a UIP design.

See Table A.9 & A.10 for list of approved connection types that must be used.

Table A.5: Standard service designs for LP networks

Allowable Length PID	≤10m	≤15m	≤23m	≤30m	≤50m	≤63m
	≤32.5kW	32mm	32mm	32mm	32mm	32mm
≤65kW (U6)	32mm	32mm	32mm	32mm	40mm	40mm
≤175kW (U16)	40mm	63mm	63mm	63mm	63mm	63mm
≤275kW (U25)	63mm	63mm	63mm	63mm	63mm	63mm
≤435kW (U40)	63mm	63mm	63mm	63mm	90mm	90mm
≤695kW (U65)	90mm	90mm	90mm	90mm	90mm	90mm
≤1085kW (U100)	90mm	90mm	90mm	90mm	125mm	125mm

Note: The values indicated can be replaced by the equivalent nominal diameter for an alternative material. Note: An allowance has been made for the presence of standard connection & termination fittings.

To be used for service connections to LP mains only, using a standard manufacturer's connection (see Table A.9 & A.10).

The lengths indicated represent the allowable plan length from parent main to meter point or to the base of a riser (where appropriate).

Table A.6: Above Ground Standard Service Laterals to Domestic Premises (LP only)

PID	Length	
	≤ 7m	≤ 15m
≤ 32.5 kW	¾" St	¾" St
≤ 65kW (U6)	¾" St	1" St

To be used when designing above ground service laterals and laterals to be connected to an above ground riser.

Service laterals with a nominated demand in excess of 6scmh should be designed in accordance with the process defined within Appendix B, taking account of the individual fittings to be used.

The lengths indicated represent the allowable plan length from parent (riser) main to meter point. Laterals in excess of the lengths indicated should only be installed with the Approval of the Responsible Person.

Table A.7: Default service design for all MP systems

PID (kW / scmh)	Length (m) < = 63m
	≤ 175 / ≤ 16
≤ 695 / ≤ 65	40mm
≤ 1085 / ≤ 100	63mm

Services more than 63m in length should be designed in accordance with the process defined within Appendix B.

Service excess flow valves should be fitted on all MP domestic services where the PID $\leq 6\text{scmh}$ (66kW). Whilst there is no requirement for an additional service isolation valve, all other MP services should be provided with service isolation valves.

Table A.8: Maximum length of pipe to be retained where a large pressure drop (>2mb) is available to be used

Maximum pressure drop Length (m) Demand	$\leq 3 \text{ mb}$			$\leq 4 \text{ mb}$			$\leq 5 \text{ mb}$		
	$\leq 10\text{m}$	$\leq 25\text{m}$	$\leq 50\text{m}$	$\leq 10\text{m}$	$\leq 25\text{m}$	$\leq 50\text{m}$	$\leq 10\text{m}$	$\leq 25\text{m}$	$\leq 50\text{m}$
$\leq 32.5\text{kW}$	20mm	25mm	25mm	20mm	25mm	25mm	20mm	25mm	25mm
$\leq 65\text{kW(U6)}$	25mm	25mm	25mm	25mm	25mm	25mm	25mm	25mm	25mm
$\leq 173\text{kW(U16)}$	32mm	63mm	63mm	32mm	63mm	63mm	32mm	63mm	63mm
$\leq 433\text{kW(U40)}$	63mm	63mm	63mm	63mm	63mm	63mm	63mm	63mm	63mm
$\leq 695\text{kW(U65)}$	63mm	90mm	90mm	63mm	63mm	90mm	63mm	63mm	90mm
$\leq 1085\text{kW(U100)}$	63mm	90mm	90mm	63mm	90mm	90mm	63mm	90mm	90mm

Note: The values indicated can be replaced by the equivalent nominal diameter, e.g. 63mmPE is equivalent to 2" metallic.

This Table should be used to evaluate the design or retention of LP services in conjunction with Table A.2 to avoid the need for Network Analysis to evaluate new demands where:

- It is proposed to retain an existing service pipe subject to an increased demand.
- It is proposed to install a new service pipe with a pressure drop >2mb (where original design results in a pipe of $\geq 6"$ NB).

The minimum service diameter for all new services (including replacement of existing services where insertion cannot be used) is 32mm, irrespective of the pressure drop used for its design. The use of a smaller pipe for new services is prohibited.

Table A.9: Approved connections for PE pipe to PE mains

Note: Where there is more than one way of installing an approved type of connection, the least cost method will form the basis of any quotation. Only standard manufacturer's proprietary fittings should be used to provide connection to a Wales & West Utilities system i.e. the use of multiple fittings to provide adequate capacity is prohibited.

Some of these techniques are not applicable for PE100 pipe.

Parent / Connection	63mm	90mm	125mm	180mm	250mm	315mm	>315mm
63mm	63mm top outlet 'service' tee – a high volume tee should be used to connect along the length of a pipe & a coupler used to connect to the end of a pipe for continuations						
90mm	63 x 63mm Cut out Tee & Reducers	Cut out tee	Branch Saddle Connection				
125mm		90 x 90 Cut out Tee & Reducer(s)	Cut out tee	Branch Saddle Connection			
180mm			125 x 125 Cut out Tee & Reducer(s)	Cut out tee	Branch Saddle Connection		
250mm		180 x 180 Cut out Tee & Reducer(s)		Cut out tee	Branch Saddle Connection		
315mm				250 x 250 Cut out Tee & Reducer(s)	Cut out tee	Cut out tee	Cut out equal tee
>315mm		315 x 315 Cut out Tee & Reducer(s)	Cut out tee		Cut out tee		

Table A.10 Approved connections for PE / Metallic pipe to Metallic mains

Parent / Connection	2"	3"	4"	6"	8"	10"	>10"
≤63mm/≤2"	Encirclement Tee/Drilling Saddle			63mm or 2" Metallic Top Tee			
≤90mm/≤3"	2"x2" Encirclement Tee & Reducer(s)	Encirclement Tee & Reducer(s)					
≤125mm/≤4"		Encirclement Tee & Reducer(s)	Encirclement Tee & Reducer(s)				
≤180mm/≤6"			Encirclement Tee & Reducer(s)	Encirclement Tee & Reducer(s)			
≤250mm/≤8"		Encirclement Tee & Reducer(s)		Encirclement Tee & Reducer(s)	Encirclement Tee & Reducer(s)		
≤315mm/≤10"			Encirclement Tee & Reducer(s)		Encirclement Tee & Reducer(s)	Encirclement Tee & Reducer(s)	
>315mm/>10"		10"x10" Encirclement Tee & Reducer(s)		Encirclement Tee & Reducer(s)		Encirclement Tee & Reducer(s)	

When considering the provision of a connection for a pipe >16" nominal diameter, a risk assessment should be undertaken. Further information is available from Wales & West Utilities (Network Strategy).

APPENDIX B

SPECIFICATION FOR THE DESIGN OF PIPES

GENERAL REQUIREMENTS

Wherever practicable, the design of a new pipe should be carried out using the relevant “Standard Design Tables” from Appendix A. This will avoid carrying out a bespoke design if the demand and the mains system support the use of a standard design.

This Appendix describes the rules to be used where this is not appropriate. The responsible person should ensure that all pipe design, or design evaluation, is carried out with regard to the requirements of T/PL/NP/16, T/PL/NP/18, and Connections Policy.

Reference should be made to the T/SP/NP/10 to identify the instances where a supply pipe should be considered to comprise a main, a service pipe or a riser. Once identified, the sections below should be used to design the pipe in an appropriate manner.

The following rules assume that no reinforcement of the existing system is required for the post-Acceptance design. In cases where reinforcement is required reference should be made to Appendix E “Assessing the Impact with Reference to the Network Analysis Model”.

GENERAL DESIGN CONSIDERATIONS

A main is a below ground pipe, or exceptionally an exposed pipe (e.g. bridge crossing) laid as an extension of, or change to, the system that supplies, or has the capability to supply, more than 2 primary meter installations.

A service is a pipe from a main up to and including the outlet of the 1st ECV to an individual meter installation. This definition may occasionally include a dual service, supplying up to two primary meter installations in one or two buildings, with no other potential connections.

A mains riser is any above ground horizontal or vertical arrangement of pipes that supplies more than two primary meter installations in an individual premises or building.

A service riser is any above ground horizontal or vertical arrangement of pipes that supplies up to two primary meter installations.

A lateral is a term in current use to describe an above ground pipe connecting a riser to a single primary meter installation

Length - The length of the pipe should be identified using MAPS or the customer’s site plan.

Velocity - For all new services operating at pressures not exceeding 7 bar the design gas velocity shall not exceed 15m/s.

For all new mains operating at pressures not exceeding 7 bar the design gas velocity should not exceed 40 m/s.

Pipe Code Table - The pipe code tables given in Appendix D should be used for the design of all new system extensions to the Wales & West Utilities network. Under the direction of the Responsible Person, other pipe sizes and efficiencies will be used when incorporating existing, or non-standard, pipes within a new design.

Route planning - the route should be planned in accordance with the recommendations and guidance given in IGE/TD/3, IGE/TD/4, IGE/GL/1 and IGE/GL/2.

Note: it is Wales & West Utilities policy to terminate services at meter positions in external meter boxes on the front face of a building or not more than 2m up the gable; or to internal meter positions within 2m of the point of entry.

Non-typical demands - Reference should be made to Appendix C for details of the design requirements for these demands.

Table B.1 Maximum design pressure drop

Note: The following values should be used for the design of all services; and they must not be exceeded.

Description / Pressure tier	Description	Maximum design pressure drop
LP (DMP ≤19mb)	New	2mb or ≤5mb ^{1 2}
	Non-Insertion replacement	2mb or ≤5mb ^{1 2}
	Insertion replacement	≤5mb ³
MP (DMP >105mb)	All	70mb
IP	All	20% of available pressure drop (capped minimum of 140mb)

The design shall include an allowance for connection & termination fittings and must remain within the defined maximum pressure drop value.

Note:

¹ Where the new service contains pipe ≥ 180mm (nominal) diameter & reference to network analysis confirms the pressure to be used

² For loads that fall within the Scope of Table A.2, the assumed parent mains pressure will be taken from the appropriate cell

³ Where the parent main has been confirmed as acceptable

B.1 DESIGN OF MAINS**B.1.1 Pipe and Fittings**

The impact of minor fittings (connections, bends, valves etc.) should be managed within the design tool through a reduction in the hydraulic efficiency of the pipe system, so no allowance should be made in the design for any fittings associated with the mains connection. However, if the Responsible Person directs that a non-standard connection (less than the nominal diameter of the extension) be used, the fitting (in the form of an extension of the pipe equivalent to the length shown within Tables B2 & B3) should be added to the network model.

The minimum supply pressure (defined within Table A.2), for multiple premises sites, is the pressure to be supplied at the outlet of the Wales & West Utilities system i.e. at the outlet face of the valve or “pup” fitting provided to allow connection to the main. The pressure loss across this fitting should not exceed more than 10% of the available pressure for the design of the system extension.

B.1.2 Mains extension designs arising from request for supply to individual premises**B.1.2.1 Pre-Acceptance Design**

For a single premises design where a main is to be provided, the main should be designed using the pressure indicated within Table A.2 or A.3 as the source pressure.

If Table A.2 or A.3 cannot be used, reference should be made to Network Analysis to identify the allowable pressure drop.

The pipe should be designed as a single diameter and should not be less than 63mm PE in diameter (or equivalent for steel pipes).

B.1.2.2 Post-Acceptance Design

Upon receipt of an Acceptance, reference should be made to Network Analysis to identify the allowable pressure drop. The “Industry least cost” solution should be identified and installed; the main should not be less than 63mm PE in diameter (or equivalent for steel pipes).

Where a C16 demand is required, the pressure to be supplied to the future connection point of this potential demand should be identified - this may be part way along, or at the end of the main. See Table A.2 or A.3 for the required pressure at that future connection point for LP and MP/IP systems.

B.1.3 Design of mains extensions to sites with multiple premises

B.1.3.1 Demands

Post-acceptance, the mains should be designed to supply the requested demand and any C16 potential demand identified by Wales & West Utilities, see Section B.1.2.2.

B.1.3.2 Connection Point Pressures

Where the level of demand does not exceed the value in Table A.2 or A.3 for the diameter of supply pipe, the indicated supply pressure should be used.

Where the requested demand exceeds these maximum values, the connection pressure on the parent main should be obtained through network analysis using the appropriate FY model (subject to the minimum value shown within Tables A.2 or A.3).

B.2 SERVICES

B.2.1 Pipe and Fittings

As indicated in the Assumptions, an allowance should be made in the design for all fittings used as part of the service installation. This should be done using the equivalent length of pipe associated with each fitting component, as shown within Table B.2 & B.3, for any pressure tier. The calculations should be carried out to ensure that pressure drop within the pipe does not exceed the maximum value shown in Table B.1.

B.2.2 Design new service

B.2.2.1 Pressure

The service should be designed using the pressure drop shown in Table B.1 and minimum pressure associated with the relevant pressure tier.

B.2.2.2 Pipe Diameter and fittings

The minimum diameter used for all new services is 32mm PE or equivalent. Figure B.1 details the rules when a composite pipe should be considered. Services up to 63m long should be designed as a single diameter.

B.2.2.3 Design of composite pipes for use in new services

Composite pipes should be designed using two diameters only, with the larger diameter as the connection pipe, and the smaller as the termination, taking into account the pressure losses arising from the equivalent lengths of fittings. Fittings should be designed to be the same size as the service pipe to which they are connected.

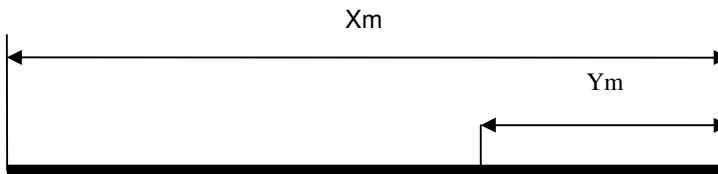

Figure B.1 Design single diameter or composite pipe

Length	Criteria	Service Configuration
$Xm \leq 63m$	N/A	Single diameter
$Xm > 63m$	Where $Y \leq 30\% X$	Single diameter pipe
	Where $Y > 30\% X$	Composite pipe

Service should not be designed as a composite service where the length of one part is very small (<30% of the total length). Consideration can still be given to reduce the termination down one size.

For example on domestic installations, it is anticipated a 3/4" x 25mm house entry tee will normally be

used; however this change in size should not be considered to constitute a composite pipe.

The equivalent lengths for fittings are to be used within composite pipe calculations are defined within Appendix B, Tables B.2 & B.3.

B.2.2.3 Remote pressure reduction

Services from MP and IP mains may be designed with the pressure reduction unit remote from the meter unit.

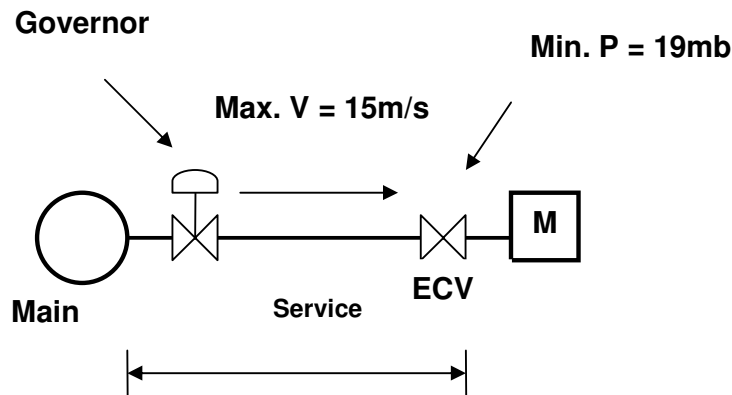

Figure B.2: Service with Remote Pressure Reduction

Where this is the case, the full pressure drop between the outlet of the pressure reduction unit and the normal pressure required at the ECV should be used in the service design. In such installations, the pressure drop associated with the LP service may exceed the standard value shown within Table B.1, and the limiting design criterion may be the gas velocity.

Table B.2: Equivalent lengths of standard service components

Fitting description	Pipe Diameter								
	<=32mm or <=1" St.	<=63mm or <= 2" St.	<=90mm or <= 3" St.	<=125mm or <=4" St.	<=180mm or <=6" St.	<=250mm or <=8" St.	<=315mm or <=10" St.	<=355mm or <=12" St.	>355mm or >12" St.
Elbow	0.5m	1m	1.5m	2.5m	3.5m	5.0m	7.0m	10.5m	14.5m
Tee – flow straight through	0.5m	1m	1.5m	2.5m	3.5m	5.0m	7.0m	10.5m	14.5m
Tee – flow through branch	1.5m	3m	4.5m	7.5m	10.5m	14.5m	19.0m	25.0m	31.0m
Swept bend	0.3m	0.45m	n/a	n/a	n/a	n/a	n/a	n/a	n/a
All valves	0.45m	0.68m	1.0m	1.8m	2.7m	4.2m	6.0m	8.0m	10.5m
Meter box entries	0.5m								

Table B.3: Service components – specific fittings

Description of connection fitting	Equivalent length	Equivalent Diameter
32mm Tee off any PE Diameter	2.0m	32mm PE
63mm Tee off any PE Diameter	4.0m	63mm PE
11/2"x 2"Flex Top Tee	4.0m	11/2" Steel
1"Metallic Top Tee	4.0m	1" Steel
Reduced branch tee	Length of "Tee – flow through branch"	Use diameter of Branch pipe

B.2.3 Increase demand in existing service

For the purposes of this document, an existing service should be assumed to exist where there is a live service identifiable in Wales & West Utilities' Engineering Asset Repository (SAP/WAM).

Where there is no record of an existing "live" service, unless a site visit identifies otherwise, it should be assumed that any existing pipe is not suitable for use to transport gas. In such circumstances, a new service design should be undertaken.

B.2.3.1 Evaluation of the configuration of an existing service

Where possible, the configuration (length and diameter) of the service should be identified from Network "as laid" records.

In the absence of this information, it should be assumed that the service is constructed in one pipe diameter, with a standard connection and termination configuration.

B.2.3.2 Assessment of Existing Design

The connection and termination fittings should be taken into account when calculating the pressure drop associated with the total increased demand.

Where the identified pressure drop exceeds that given for the relevant pressure tier in Table B.1, the existing service should be replaced, with the service being designed to meet this defined pressure drop limit.

B.2.3.3 Velocity

Following an increase in demand, an existing service should not be replaced because of the maximum velocity being exceeded.

B.3 Riser design and premises with banks of meters

B.3.1 Pressure

The pressure at the extremity of a mains riser should be the same as the system minimum mains design pressure.

B.3.2 Design of riser and associated approach main

B.3.2.1 Designs connecting to LP mains

The approach main and above ground mains riser should be designed as a single unit and be based on the available pressure drop in the parent main or, where appropriate, the standard pressure taken from Table A.2.

B.3.2.2 Designs connecting to MP or IP mains

Approach mains should be designed as a single unit using the available pressure drop.

The available pressure drop should be the difference between the outlet of the pressure reduction unit and the minimum pressure at the extremity of the riser.

B.3.2.3 Fittings

No allowance should be made in the design of the mains riser or the approach main for the presence of fittings.

B.3.2.4 Lateral Design

Where the use of Table A.6 is not possible, for example the demand or length exceeds the values, individual laterals should be designed using the service calculator, with a maximum pressure drop of 2mbar. Laterals should be designed as single diameter pipes, with an allowance made for the presence of fittings.

B.3.3 Design of above ground rails (also known as above ground manifolds)

This Table should be used for the design of single column above ground risers, when used with standard design above ground service laterals. It should also be used for the design of manifolds i.e. blocks of flats with ground floor banks of meters.

Table B.4: Standard designs for single column risers and manifolds

Length \ Maximum Design demand	≤ 15m	≤23m	≤30m	≤50m
≤65kWh	32mm / 1" St	32mm / 1" St	32mm / 1"St	63mm / 2"St
≤175kWh	63mm / 2" St	32mm / 1"St	32mm / 1"St	63mm / 2"St
≤275kWh	63mm / 2" St	63mm / 2"St	63mm / 2"St	63mm / 2"St
≤435kWh	63mm / 2" St	63mm / 2"St	63mm / 2"St	90mm / 2"St
≤695kWh	90mm / 2" St	63mm / 2"St	63mm / 2"St	90mm / 2"St
≤1085kWh	90mm / 2" St	90mm / 2"St	90mm / 2"St	N/A

- To be used to design single column above ground risers and multiple, above ground manifolds connected to LP mains
- Assumed that the nominal mains connection fitting is not less than the downstream pipe
- The lengths indicated represent the total length from parent main to end of "main", the mix of below/above ground pipe work is not considered significant
- Total diversified demand is assumed to be at end of "main"

Figure B.4: LP above ground rail, meters at separate locations- typical configuration

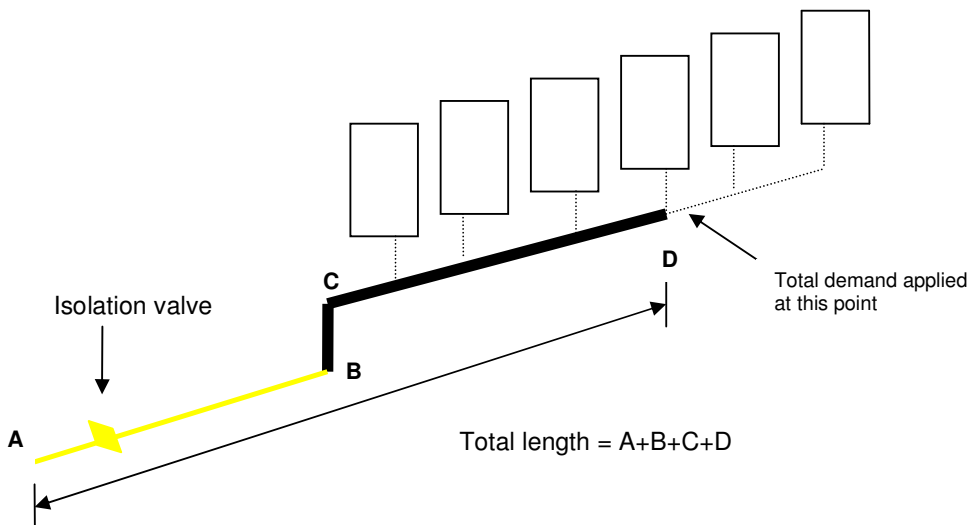

Service laterals should be designed in accordance with the requirements of Table A.6.

B.3.3.1 Bespoke Design

Where it is not possible to design the rail using this approach, it should be designed in accordance with Section B.3.2.1.

B.4 DESIGN OF CONNECTIONS TO A WALES & WEST UTILITIES GRID PARENT MAIN

Refer to Tables A.9 and A.10.

Where a GT has stipulated a connection diameter less than that given in Table A.4, the GT should be asked to confirm the requirement before a quotation is issued.

Where a UIP indicates a diameter less than the value within the Tables, the design should be evaluated to confirm they are suitable, and should be rejected where appropriate. The Responsible Person should ensure that C16 demands are taken into account before confirming that connection should progress.

APPENDIX C

EVALUATION AND DESIGN OF CONNECTIONS TO NON-TYPICAL DEMANDS

Where necessary, the relevant demand profile / gas use information should be provided under the Business Rules to allow the provision of a practical design solution. Where, at the outset of the design process this information is incomplete, a number of simplifying assumptions may be applied resulting in a sub-optimal design solution and additional assessment as the type and nature of the installation becomes clear.

The information that is required is shown in Tables C.1 and C.2.

Table C.1: Where a non-typical demand profile is identified

The details in this table represent the basis for discussion with the end-user or his representative.

To identify the proposed profile of gas use, it is necessary to understand the time(s) of day and year at which the gas demand is required and if the demand varies from this level at the other key times/conditions of the day and year.				
Please complete the following boxes as is appropriate for the demand.				
Period	Please indicate with a tick the times of the day and year when the peak demand may occur			
	0600 – 1000	1000 – 1600	1600 - 2000	2000 - 0600
Beginning Oct – end March				
Beginning June – end August				
Other periods of the year				

Table C.2: Where a compressor or booster is identified as being installed

Peak Instantaneous Demand to be compressed and the pressure required:kW/m ³ /hr	mbar/bar	
Compressor Types (Reciprocating/Fan/Screw/Booster/Other):			
Number of Compressors/Boosters and the Peak Instantaneous Demand to each excluding standby:	No.:		Flow	Plant 1.....kW/m ³ /hr Plant 2.....kW/m ³ /hr Plant 3.....kW/m ³ /hr
Time taken to achieve full load from start up	Time taken.....seconds			
Profile provided for non linear start up profile	Y/N/NA			
Number of burners to be installed?				
Will burners be operated in parallel?	Y/N/NA			
Typical burner stages	Start up/ Pre-purge	Pilot fire	Low fire	High fire
Flow as % of burner's PID - burner 1				
Minimum time for each stage (s) - burner 1				
Flow as % of burner's PID - burner 2				
Minimum time for each stage (s) - burner 2				
Flow as % of burner's PID - burner 3				
Minimum time for each stage (s) - burner 3				

Where the customer has identified a non-typical demand, it should be assessed using network analysis and, where appropriate, National Grid's design assessment tool 'CompAss' or approved equivalent.

The following description refers to the use of CompAss, but it is assumed that the same principle will be used where an equivalent and approved tool is used.

C.1 Assessment of individual non-typical demands

Where a demand is to be used at a specified off-peak period only, its impact should be assessed, using the relevant model, against the specified period. The limited period identified will be clearly stated on all quotations correspondence as a condition of supply.

For low pressure networks or other networks where source pressures are reduced at off-peak conditions, the impact of the demand should be assessed against the four standard conditions see Table C.3.

Table C.3: Conditions to be modelled for non-typical off-peak demands on LP networks and direct fed MP demands

Source Settings	Standard Conditions	Scale for Demand Types		
		Domestic	Commercial	Industrial
Winter Day	Peak Hour, Peak Day Pressure	100%	100%	100%
Winter Night	Minimum Hour, Peak Day Pressure	40%	40%	100%
Summer Day	Peak Hour, Minimum Day Pressure	20%	20%	100%
Summer Night	Minimum Hour, Minimum Day Pressure	10%	10%	100%

- The figures shown in this table shall be used to ensure consistent design output is provided. No additional demand modifications should be made to model demands being absent, or present, for the time the analysis being carried out.
- Any “Commercial” demand should be assumed temperature sensitive and any “Industrial” demand as being constant throughout the day and across the year.
- For MP networks assume downstream demand is per the domestic tag For the design of single and composite pipes and mains, see Appendix B.

C.2 Supplies to elevated pressure demands

Contact should be made with any consumers requesting an elevated pressure to identify when this pressure is required.

Where a specific period is specified, analysis should be undertaken to identify how it can be provided. Where the customer is not able to define a period the range of pressures associated with the point of connection should be identified using the settings shown in Table A.6

C.3 Supplies to CSEPs containing non-typical demands

Where a CSEP site includes a non-typical demand or a demand that has downstream compressor or booster or has requested specific off-peak pressures, the GT should be requested to supply either:

- The demands it anticipates at the four standard conditions (see Table C.3), or
- The demands it anticipates at specific times requested.

These demand levels should be applied to the relevant model(s) and the GT provided with the resultant pressures at the ISEP connection.

Where a GT is unable to specify the demand details, the demand types should be assumed to be non-temperature sensitive attached to a reciprocating compressor. The assumption must be stated within the quotation.

The demands should be scaled for the four standard conditions in accordance with the scaling factors given in Table C.3.

Additionally, where a GT has identified that the CSEP site includes a supply to a compressor or booster, the four standard pressures should be quoted. The GT should be requested, as part of the Quotation, to confirm the supply pressures are adequate, and the impact of the demand at the worst-case condition will not materially affect the parent system.

Where higher, peak or off-peak, pressures are required by the GT than are indicated as being available, reinforcement should be evaluated in accordance with the requirements of this document and quoted in accordance with TCPM, see Appendix E “Assessing the Impact with Reference to the Network Analysis Model”.

The off-peak demand data should be retained for future modelling off-peak conditions and maintenance

of the required pressures.

The connection to the GT site should be designed in accordance with Appendix B, or as requested by the GT.

C.4 Assessment of supplies using CompAss

Appendix C, Table C.4 identifies the types of demand for which CompAss analysis is required.

Table C.4: Demand Types for use with CompAss

Demand Type	Compass (or equivalent tool) assessment required?
Non-typical consumption profile to individual demand	No
Non-typical consumption profile to CSEP	No
Downstream compression to individual demand	Yes
Downstream boosting to individual demand	Yes
Elevated pressure to individual demand	No
Downstream compression or boosting to CSEP	In agreement with GT

For connections to all pressure tiers below 7bar, when using CompAss, network analysis of the appropriate FY models and the relevant conditions should be undertaken to derive the steady state pressures available in the network.

Appendix C, Table C.5 identifies the typical periods when the network is likely to experience maximum pressures under shut down conditions and minimum pressures under start up conditions. Reference to the table ensures that the level of demand which causes a rapid change and the service design will not give rise to unacceptable pressures in the network at these times.

Note: This list is not comprehensive and the Competent Person should ensure that the “worst case” condition is understood and account taken of it i.e. the condition may depend upon the network and the type of pressure management implemented.

Table C.5: Typical worst-case pressure conditions for assessment in CompAss

Assessment	Type of network pressure management	Source Setting	Condition
Start-up	Fixed	Winter Day	Peak Hour, Peak Day Pressure
	Clock pressure	Winter Day	Peak Hour, Peak Day Pressure
	Computer managed (closed loop control or pressure profiling)	Variable	Min Hour, Min Day Pressure
Shut-down	Fixed	Summer Night	Min Hour, Min Day Pressure
	Clock pressure	Winter Night	Min Hour, Peak Day Pressure
	Computer managed (closed loop control or pressure profiling)	Variable	Peak Hour, Peak Day Pressure

C.4.1 Demand factors for use in Compass

To evaluate the impact of the specific compressor, the appropriate factor, as shown in Table C.6, should be applied to the steady state flow when using CompAss:

Table C.6: Factors for use in Compass

Type	Factor
Booster	0
Reciprocating compressor	2.3
All other compressor types	1.0

Applying this factor takes account of the different ways that the equipment operates, and ensures that its impact is known.

C.4.2 Pipes for input into Compass

Wherever possible the mains and service assessment option of CompAss should be used to ensure that the impact on the parent main is taken into account. This allows the maximum benefit of the dissipation of the wave to be assessed and lessens the distance to any critical point in the network where there is a constraint on the pressure required.

Rules for the ratio of service length to mains length are detailed below and should be applied unless specifically directed by the Responsible Person. Where the application of these rules is not possible, the impact on the service alone should be evaluated.

C.4.2.1 Ratio of Service Length to Mains Length

The following constraints should be taken into account when using Compass to evaluate the impact of a compressor / booster.

- The maximum length of the main, upstream and downstream from the service, should be as far into the mains system as possible, but not greater than 10 times the length of the service.
- The minimum length of the main, upstream and downstream from the service, is not less than the length of the service.
- The cut off points for the main are a change in pipe diameter / material, or a pipe junction / connection.
- Where the service connection is supplied from a number of directions, the direction of flow should be taken to be the one with the greatest supply volume.
- Where the minimum length of the main, upstream or downstream from the service, is less than the length of the service, the CompAss “service” option should be used.
- Where the direction of the flow of gas to the service is from both directions, the CompAss “service” option should be used.

C.4.3 Transient pressure constraints for the assessment of non-typical demands

The maximum permissible transient pressure constraints, shown in Table C.6, should not be exceeded when evaluating the impact of a non-typical demand. These values should be used within CompAss in the appropriate boxes.

Table C.7: Transient Pressure for the Assessment of Non-Typical Demands

Constraint		Pressure Tier	Pressure Level		
Transient pressure at connection point	Maximum Pressure	LP	75mbar		
		MP	2bar		
		IP	7bar		
	Minimum Pressure	LP – highest of:	21mbar ¹	22.75mbar ²	
		MP	Minimum 6 minute mains design pressure		
		IP			
Transient pressure at meter point	Maximum Pressure	LP	75mbar		
		MP	2bar		
		IP	7bar		
	Minimum Pressure	LP	19mbar ¹	20.75mbar ²	
		MP	Minimum 6-minute system design pressure ³		
		IP			

Notes:

- 1 - Systems designed pre 1997.
- 2 - Discrete systems designed post 1996.
- 3 - See Appendix A Table 10 - LOP.

C.4.4 Service design for supplies to demands requiring CompAss assessment

The following rules should be applied to the design of the service:

C.4.4.1

The service should be designed using the PID identified by the customer, and include the sum of any compressed demand plus all other demands.

C.4.4.2

The diameter of the service must not exceed the diameter of the main from which the connection is taken.

The table below represents the standard approved PE & steel design pipes associated with CompAss. Pipes other than those shown are not approved for use and must not be employed for quotations purposes. The equivalent nominal diameters in each row represent the maximum size of the parent main to which connection can be made, whilst meeting the requirements of this Instruction.

It has been assumed that only metric equivalent steel pipe will be used for service installation in the column showing the maximum permissible service diameter.

Table C.8 Standard pipe diameters - comparison table

To ensure that the relevant non-PE diameters are clearly understood, reference may be made to the following table.

Standard design pipe nominal diameters - default comparison

PE (mm)	Mettallic (Metric)	Metallic (Imperial)	Maximum service diameter PE/Metallic)
16	-	-	-
20	-	1/2"	-
25	20mm	3/4"	-
32	25mm	1"	-
63	50mm	2"	63 / 50
90	80mm	3"	90 / 80
125	114mm	4"	125 / 114
180	168mm	6"	180 / 168
250	219mm	8"	250 / 219
315	273mm	10"	315 / 273
355	324mm	12"	355 / 324
400	406mm	15"	400 / 406
450	425mm	16"	450 / 425
500	440mm	17"	500 / 440
-	457mm	18"	457
-	508mm	20"	508
-	610mm	24"	610

C.4.4.3

The initial service should be designed using the design criteria for the relevant pressure tier. The rules for the use of single and composite pipes should adhere to, see Appendix A.

C.4.4.4

The resulting service layout should be input into Compass, together with the appropriate mains. Where the assessment of this design results in system constraints being violated, the diameter(s) of the service should be increased and the results reassessed.

Where modifying the service pipe diameter (bearing in mind the constraints on size of service) does not provide an acceptable solution, the provision of supply from a higher-pressure tier(s) should be considered. Where this is not possible, the customer should be advised that the supply couldn't be provided without control being provided for the start up and/or shut down of the compressor.

C4.4.5

Reference should be made to Tables A.9 & A.10 for the details of the acceptable connection fittings and methods to be used.

C4.4.6

Where changing the diameter of the service does not prevent in the system constraints being violated, and a feasible higher-pressure tier connection is not available, the "ramp rate" will be identified and the customer advised as one of the conditions of supply (the original service design (item 4.4.1) will be quoted when defining a "ramp rate").

The ramp rate is a coarse term to describe the cycle that starts with the booster turning on to pressurise the downstream pipework to 100% burner flow.

For conventional burner type appliances e.g. boilers there are typically 4 stages, booster on to pressurise pipework (<1% flow), burner start-up / pre-purge (<1% flow), burner pilot (<20% flow), burner low fire <40% flow) and burner high fire (100% flow).

Each stage can be modelled in Compass providing the information is available. The ramp rate can be calculated from the formula:

$$T = 0.436 * D,$$

Where T is the ramp rate time (seconds) & D = upstream mains diameter (mm)

For example, for a 250mm PE SDR17 pipe (ID 220.75mm),
the Ramp Rate = $0.436 * 221 = \underline{96 \text{ seconds}}$

Therefore, where a constant ramp rate is maintained for at least 96 seconds, no additional control is required to overcome the start-up/shut down affect.

Note: the “ramp rate” is, generally, only affective on compressors which are not feeding a burner i.e. process loads / NGV filling stations etc.

C.4.4.7

“Snubbers” or other short length increases in pipe diameter should not be used to mitigate the impact of compressors or boosters, as they are not considered effective in dissipating the transient wave.

C.5 Quotation

All assumptions made during the assessment of non-typical demands will be recorded and made clear in any quotation to the customer.

APPENDIX D

SPECIFICATION FOR STANDARD PIPE CODE TABLE FOR NEW LAY PIPES

When undertaking the design of new system extensions or the review of a 3rd party submissions to be connected to a Wales & West Utilities network, the following pipe parameters should be used. As appropriate, Wales & West Utilities may allow supplementary pipes to be added to the list, i.e. where a UIP proposes to use a non-standard pipe size, which is considered suitable for adoption.

Table D.1: PE Pipes

Nominal Diameter	Material	Internal Diameter	SDR	Pipe Efficiency Factor		
				Electro Fused & Butt Fused De-beaded	Butt Fused Non De-beaded 6	Butt Fused Non De-beaded 12
16	PE	11.15	7	0.97	-	-
20	PE	15.15	9	0.97	-	-
25	PE	20.15	11	0.97	-	-
32	PE	25.75	11	0.97	-	-
40	PE	32	11	0.97	-	-
63	PE	50.9	11	0.97	-	-
90	PE	79.2	17	0.97	-	-
125	PE	101.3	11	0.97	0.89	0.93
125	PE	110.3	17	0.97	0.89	0.93
180	PE	145.95	11	0.97	0.89	0.93
180	PE	158.75	17	0.97	0.89	0.93
250	PE	202.95	11	0.97	0.89	0.93
250	PE	220.75	17	0.97	0.89	0.93
250	PE	226.2	21	0.97	0.89	0.93
315	PE	255.75	11	0.97	0.89	0.93
315	PE	278.25	17	0.97	0.89	0.93
315	PE	285.0	21	0.97	0.89	0.93
355	PE	288.1	11	0.97	0.89	0.93
355	PE	313.5	17	0.97	0.89	0.93
355	PE	321.19	21	0.97	0.89	0.93
400	PE	327.27	11	0.97	0.89	0.93
400	PE	353.20	17	0.97	0.89	0.93
400	PE	361.90	21	0.97	0.89	0.93
450	PE	407.14	21	0.97	0.89	0.93
500	PE	409.09	11	0.97	0.89	0.93
500	PE	441.7	17	0.97	0.89	0.93
500	PE	452.38	21	0.97	0.89	0.93

The above values are common for both the design of new, and review of existing, PE pipes.

Table D.2: Steel Pipes

Nominal Diameter	Material	Internal Diameter	Pipe Efficiency Factor		Mains or Service Design
			Fillet Welded Screwed	Butt Welded	
0.5	ST	19.93	0.86	-	S
0.75	ST	19.67	0.86	-	S
1	ST	26	0.86	-	M
1.25	ST	33.92	0.86	-	M
1.5	ST	38.67	0.86	-	M
2	ST	49.86	0.97	0.97	M
2.5	ST	65.43	-	0.97	M
3	ST	78.13	-	0.97	M
4	ST	103.53	-	0.97	M
6	ST	157.51	-	0.97	M
8	ST	206.38	-	0.97	M
10	ST	260.35	-	0.97	M
12	ST	311.15	-	0.97	M
16	ST	390.55	-	0.97	M
18	ST	441.35	-	0.97	M
20	ST	492.15	-	0.97	M
24	ST	593.75	-	0.97	M
30	ST	739.75	-	0.97	M
32	ST	793.75	-	0.97	M
36	ST	889	-	0.97	M
42	ST	1,066.8	-	0.97	M
48	ST	1,225.55	-	0.97	M